



IDRASCREEN™

High capacity compact screening units
for the pre-treatment of waste waters



Solutions & Technologies



IDRASCREEN™

The only really self-cleaning screen

IDRASCREEN™ represents the range of high capacity self-cleaning screen filters for the waste waters pre-treatment. It is properly equipped with an inner washing system with low/medium pressure to do the periodical cleaning to avoid clogging phenomena, reducing cleaning maintenance and high costs.

IDRASCREEN™ is a product of US research and technology. It has been designed to solve the problems that traditional methods was not able to. Separating solids from processing and drainage water has always been a serious problem in many industrial sectors and at wastewater treatment plants. This problem has been faced by using various types of machinery and the results have been at times partially satisfactory and at others extremely disappointing: cylindrical separators cleaned by mechanical or spray system, vibrating sieves, static screen and various other devices have proved not to be able to solve the problems of solids separation.

IDRASCREEN™ results have exceeded expectations and from 1973 it has been introduced in a lot of applications, proving to be **the only really self-cleaning screen**, capable of working for many weeks with no assistance and little or no maintenance.



IDRASCREEN™ comprehends both ECO and GF series. IDRASCREEN™ GF can be equipped with special movable blade scraper and manufactured in special execution suitable for installation directly on the channel.



Materials

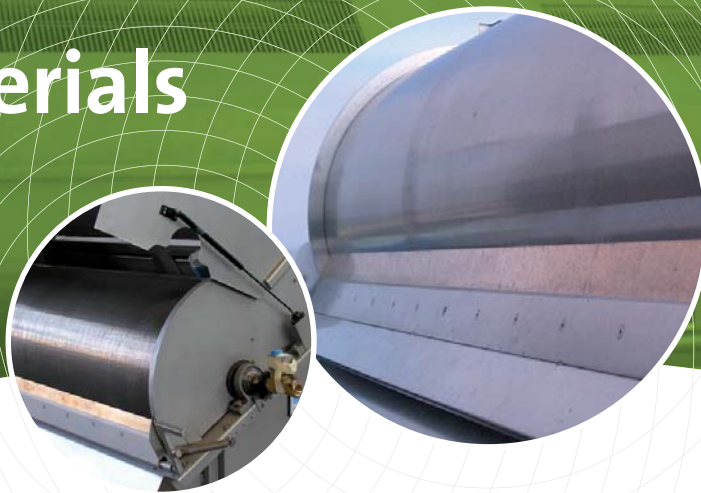

VWS Italia, in co-operation with respected materials research centres, selects the most suitable materials for the safe management of aggressive liquids.

Austenitic stainless steel AISI 316L

(Number: 1.4435 - X2 CrNiMo 18-14-3)

Austenitic weakly bound structure, non-hardening, non-magnetic. The low percentage of Carbon in this alloy reduces the risk of intergranular corrosion at high temperatures.

Uses: alkaline liquids, acid liquids (pH>4) with a low percentage of chlorides, oil emulsions, liquids from flexographic printing.

Austenitic stainless steel AISI 304

(Number: 1.4410 - X2 CrNiMo 25-7-4)

Austenitic weakly bound structure, non-hardening, non-magnetic. The low percentage of Carbon in this alloy reduces the risk of intergranular corrosion at high temperatures.

Uses: alkaline liquids, acid liquids (pH>3) with a low percentage of chlorides, oil emulsions, liquids from flexographic printing.

IDRASCREEN™ technical reports





Advantages

- Low initial investment and low installation costs
- Low operating costs
- High capacity with very reduced dimension (from 1/3 to 1/5 of the floor space of other screens)
- Long life with little or no maintenance (the construction is simple and made entirely of corrosion resistant 304 and 316L stainless steel)
- Low power costs and no consumption of additional water
- Reduction of clogging phenomena
- More efficient separated solids draining than in traditional filters with lower costs for removal and recycling of screenings.





Components

IDRASCREEN™ GF ed ECO, seen in lateral section, are presented in this way.

Frame, distribution and collecting base are made entirely of AISI 304 and AISI 316L stainless steel and sized to guarantee sturdiness and long life. To provide greater flexibility the chassis is divided into two parts: the headbox and screen section (which can work as an independent unit) and the bottom collecting portion.

The unit without the collecting base can be fitted directly on canals or pumping stations. If discharge is to be piped, use of the storage tank is advisable.

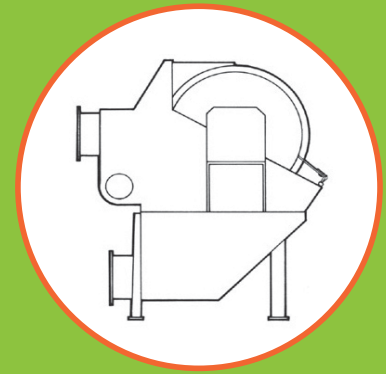

The **cylinder**, made entirely of AISI 304 stainless steel, is the heart of the machine and the result of vanguard construction technology. Wedgeshaped wire is wrapped around a supporting structure to form a helical coil, leaving free spaces of from 0,25 to 2,5 mm according to the utilizer's requirements.

The wire have a trapezoid shape which have been specially designed to obtain high specific flow values with a minimum loss of head (Venturi effect).



The **inner washing system** is fed by industrial water at low/medium pressure. It is composed by fixed nozzles and the cleaning is made periodically not continuously.

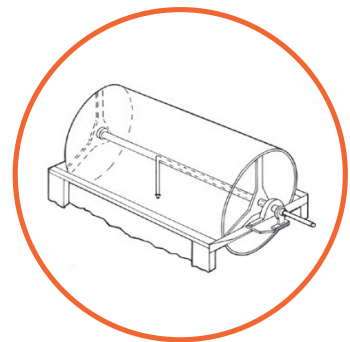

The **doctor blade** has the function to remove the solids trapped on the surface of the screen. It is made of special corrosion-proof material considerably softer than the material of the cylinder.

Motorization: the standard execution includes fitting of a geared motor.





How IDRASCREEN™ works

The influent to be screened is introduced into the headbox which is specially designed to slow down the flow and to distribute it. The influent inlet overflows a sealed weir into the rotating cylindrical screen.

The solids are retained on the outside screen surface and removed by the doctor blade.

The screen effluent passes again through the cylinder, carries on an efficacious backwashing of the screen openings.

Thanks to this, the portion of the screen cylinder screen to be fed is always perfectly clean.

Moreover, the backwash avoids the mucilage formations inside the cylindrical screen.

IDRASCREEN™ is properly equipped with an inner washing system with low/medium pressure to do the periodical cleaning.

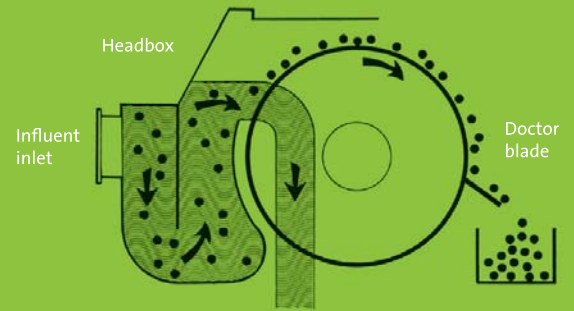

Views

- 1. Influent inlet
- 2. Screen cylinder
- 3. Drive unit
- 4. Doctor blade
- 5. Headbox
- 6. Bottom emptying
- 7a. Effluent outlet (standard position)
- 7b. Effluent outlet (position on request)
- 7c. Effluent outlet (position on request)
- 7d. Effluent outlet (position on request)

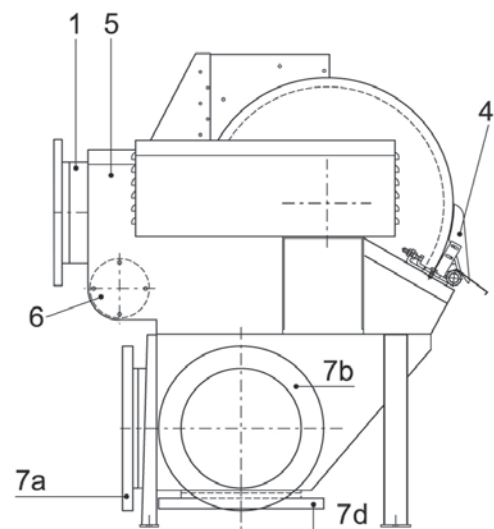
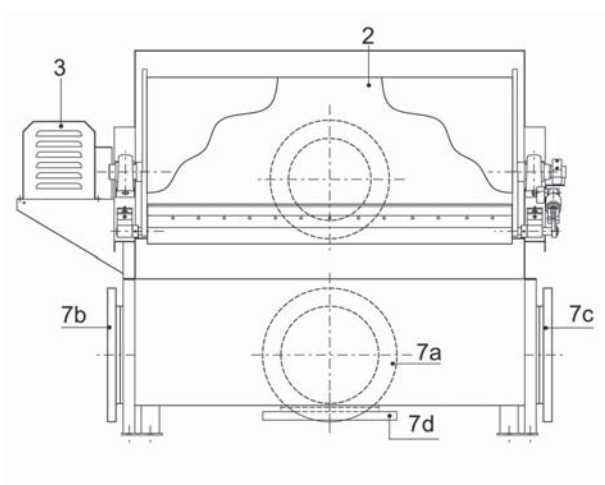

Accessories

- Movable blade system
- Feed flange for canal fitting
- Protection cover
- Frontal protection mesh
- Level control switch
- Electrovalve on washing system line



Application fields

Industrial:

- Meat processing
- Seafood processing
- Fruit and vegetable processing
- Sugar mills
- Pig stock
- Poultry processing
- Beer production
- Wine production
- Pharmaceutical industry
- Pulp & paper
- Chemical industry
- Tanneries
- Slaughter-houses
- Dewatering paint sludges
- Textile
- Canning
- Plastics industry

Municipal:

- Fine screening
- Replace primary clarifiers
- Storm water overflow
- Ocean outfall systems
- Sludge screening



Veolia Water Solutions & Technologies Italia S.r.l.

Solutions Division

Via Pra' di Risi 3, 33080 Zoppola (PN)
Tel. +39 0434 516311 • Fax +39 0434 516310
solutions@veoliawaterst.it

Industrial Design & Build Division

Largo A. Cacciari, 1/B • 1/D, 43100 Parma (PR)
Tel. +39 0521 247672 • Fax +39 0521 463992
dbindustriale@veoliawaterst.it

www.veoliawaterst.it